



CALVERT™
PUBLICATIONS

1st grade | Unit 1



SCIENCE

LIGHT SCIENCE 101

Introduction |1

1. Look for Light	2
Sources of Light 3	
Light as Energy 4	
Light and Dark 6	
Using Light to See in the Dark 7	
Turn on the Lights 8	
Lights at Night 9	
Self Test 1 10	
2. Light Can be Blocked	12
Transparent Objects 13	
Translucent Objects 14	
Opaque Objects 15	
Shadows 16	
Shadows Can Be Big or Small 18	
Sun and Shadows 19	
Self Test 2 20	
3. Light Can Travel	23
Ways Light Moves 24	
Smooth and Shiny Objects 26	
Mirrors Reflect Light 27	
Keeping Light Out of Your Eyes 28	
Design a Solution 30	
Make Your Design 31	
Self Test 3 32	

Test |Pullout



804 N. 2nd Ave. E.
Rock Rapids, IA 51246-1759

© 2019 Glynlyon, Inc. All rights reserved.

Author:
Glynlyon Staff

Editor:
Glynlyon Staff

Illustrations and Layout:
Glynlyon Staff

Media Credits:
Pages 12, 13, 15, 21, 22, 33: © Serhii Brovko,
Getty Images.

Learn with our friends!



When you see me, I will help your teacher explain the exciting things you are expected to do.



When you do actions with me, you will learn how to write, draw, match words, read, and much more.



You and I will learn about matching words, listening, drawing, and other fun things in your lessons.



Follow me and I will show you new, exciting truths that will help you learn and understand what you study. Let's learn!

LIGHT



Everywhere you look,
light is there.
You use your eyes to see
shadows on the ground.
A mirror reflects back at you,
light is all around.

Objectives

Read these objectives. They will tell what you will be able to do when you have finished this workbook.

1. I can identify light as energy.
2. I can tell what causes shadows.
3. I can tell what reflects light.
4. I can design a solution to a problem.

My name is

I will learn about light.

1. LOOK FOR LIGHT



Color in each light source mentioned in the poem.

The bright yellow sun
Lights each day.
The sun lights the moon at night,
When the sun goes away.

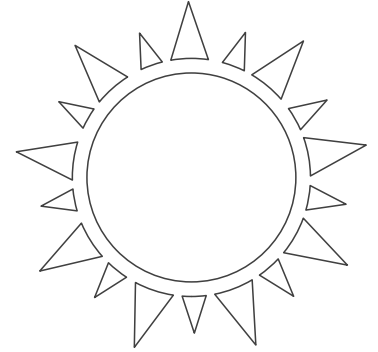

When night comes,
Lamps blaze and candles glow
They light inside my house
As outside, darkness grows.

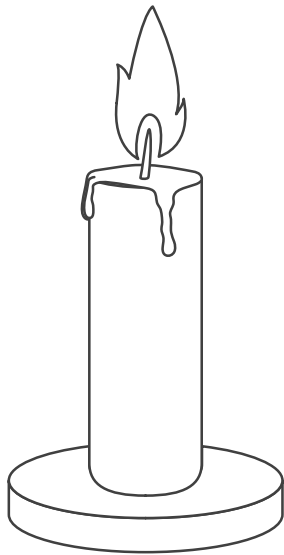
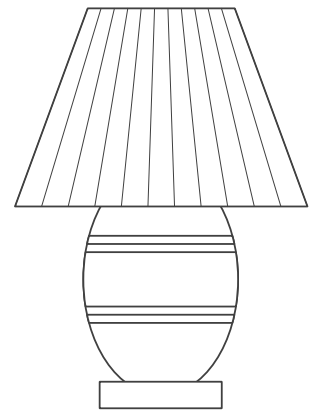

Then the sun rises,
Colors come into view
What was dark becomes light,
And can be seen by me and you.

Sources of Light

Light helps us see. There are many sources of light. The sun gives us light. Light bulbs and flashlights also help us see. Light can come from many different sources.



Circle the objects that are a source of light.

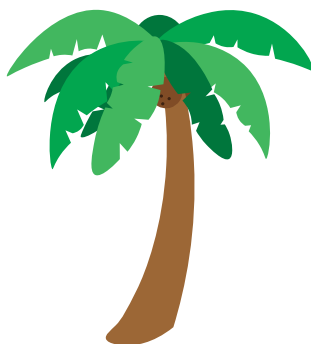
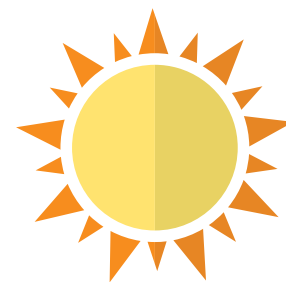
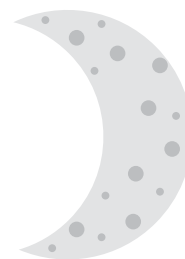
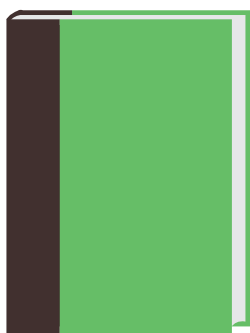

Light as Energy

Light is a form of energy. Energy is how things change and move. There are many types of energy. We see energy as light with our eyes.



All of these are sources of energy. Color in the sources of light energy.

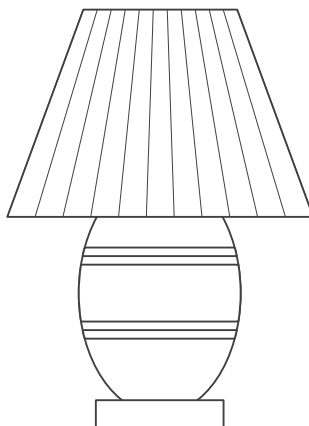
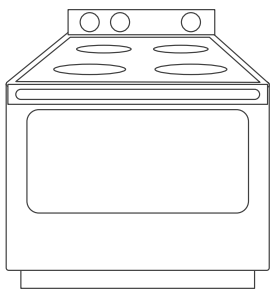
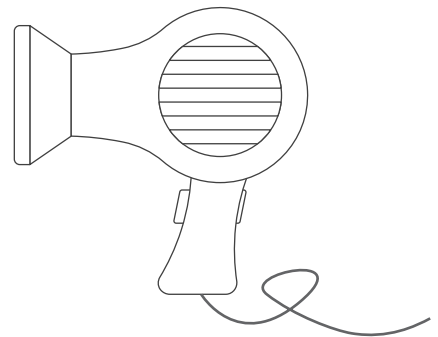
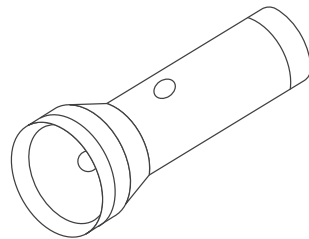
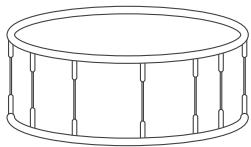
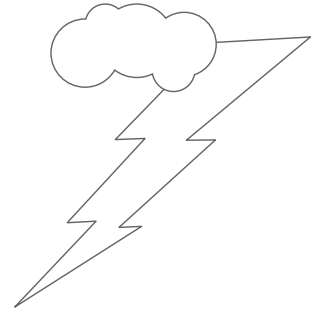
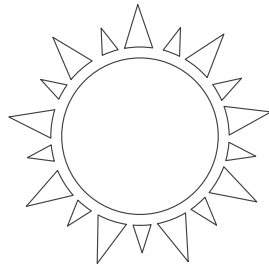

Light can make places look different.
Look at the pictures of the bedroom.



This picture shows the
bedroom with the lights on.



This picture shows the
bedroom with the lights off.



Write the word.

makes the room look different.



Trace the sentence.

Light is a type of energy.

Light and Dark

Things look different in the light and dark. You can see objects that give off their own light when it is dark.



Circle the object that you would see best in a dark room.

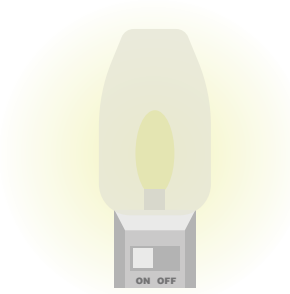

Put an X on the activities that need light.



Using Light to See in the Dark

It is difficult to see in the dark. We can use light to help us see.



Circle the light sources that you see.

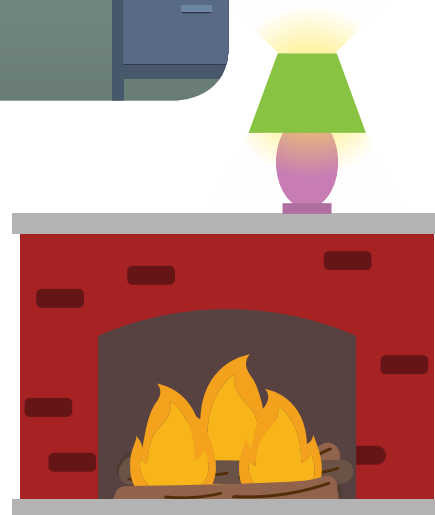

Read the sentence. Write the word.

can help

me see in the dark.

Turn on the Lights

Light can show us objects that are in the dark. We could not see objects without light.



Look at each picture. Draw an object that you could see because of light. The first example is done for you.

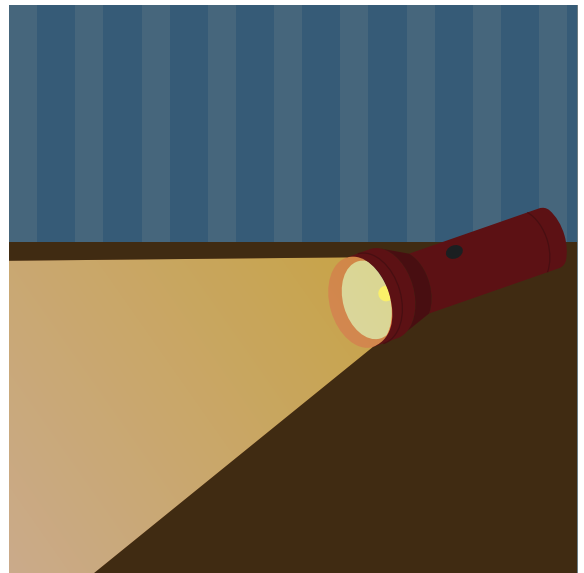

Lights at Night

Light can show us objects that are in the dark.
We could not see objects without light.



**Use your eyes. Find all the lights in the picture.
Color them in. Then color the rest of the picture.**



Talk about light.



**Before you take the Self Test, study what you have read
and done.** The Self Test will check what you remember.

SELF TEST 1

Each answer = 1 point

Look at each line of items. Put an X over the item that provides light.

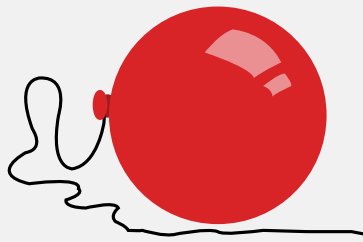
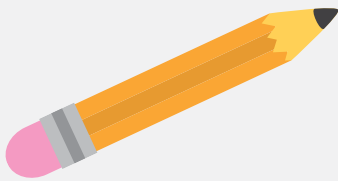
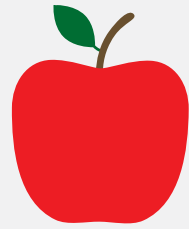
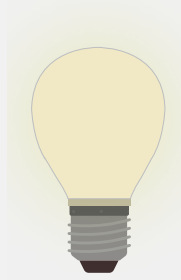

Circle every source of light in the picture.

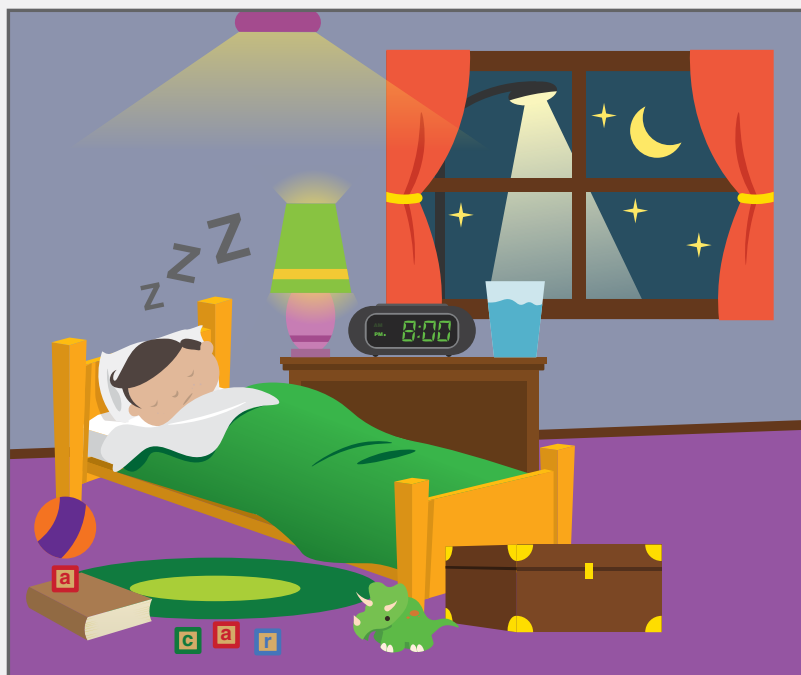

Circle the objects that can be seen in a dark room.



Circle the object that gives off its own light.

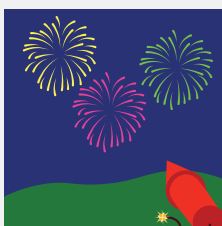

✓ Teacher Check

Initial Date

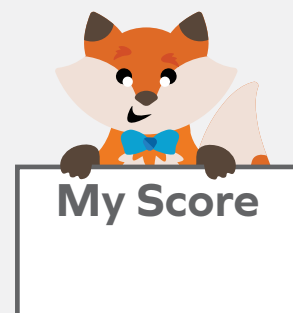



TM

CALVERT
PUBLICATIONS

804 N. 2nd Ave. E.
Rock Rapids, IA 51246-1759

877-878-8045
www.calverteducation.com

CS0101 – Jun '19 Printing

ISBN 978-0-7403-3911-0



9 780740 339110